

Q-327



SVE BULLETIN

SPECIAL VEHICLE ENGINEERING – BODY BUILDERS ADVISORY SERVICE

E-Mail via Website: www.FordBBAS.com (click "Contact Us")

Toll-free: (877) 840-4338

QVM BULLETIN: Q-327

DATE: 13 / October / 2020

F-Series – Relocation Kit for Roof-mounted Dual Antennae

| REVISION | UPDATE | REVISION DATE |
|----------|-----------------|---------------------|
| Q-327 | INITIAL RELEASE | 13 / October / 2020 |

MODEL(S) AFFECTED:

2020 – 2022 F250/F350/F450/F550/F600 Super-Duty

ISSUE / DESCRIPTION:

Beginning in MY2020, Super Duty trucks are equipped with dual roof-mounted antennae that provide modem/cellular, satellite radio and GPS functions. It is recognized that various commercial vehicle upfits involve the use of aerodynamic fairings or other equipment that would obscure the “sky view” that roof-mounted antennae require. There is now available an antenna relocation service kit which provides two replacement antennae that can be mounted on top of the upfit body in a location with a clear sky view.

Service Kit Part Number

LC3Z – 18813 – B*

* See Ford dealer for latest part level.

Service Kit Contents

- A, B) LH and RH replacement antennae.
- C, D) LH and RH antenna mounting plates.
- E, F) LH and RH extension harnesses (22’).

Roof-mounted Antennae (Super Duty):

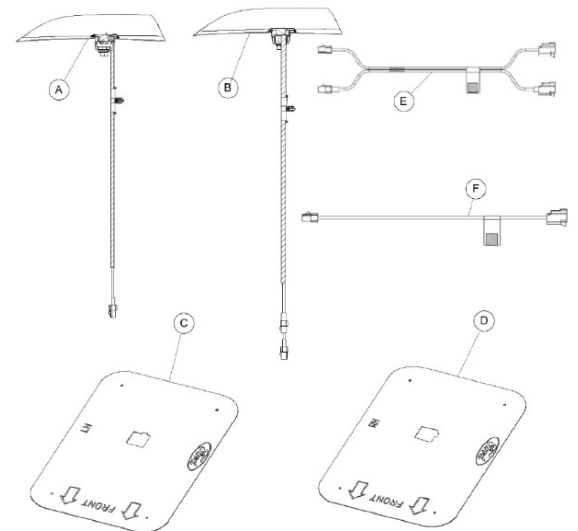
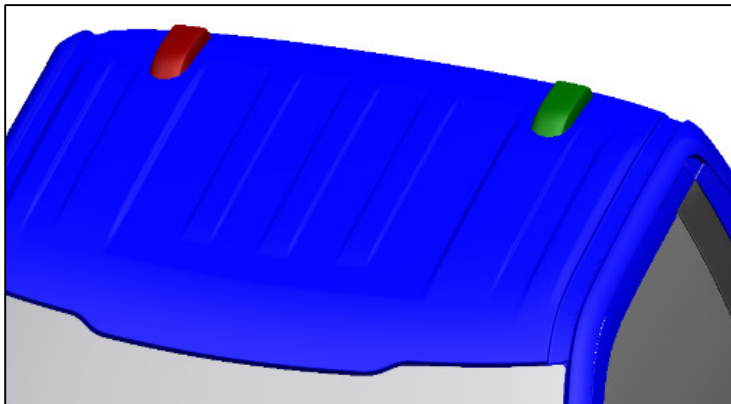

Refer to the Body Builder Layout Book for additional guidelines and recommendations. If you have any questions, please contact the [Ford Body Builders Advisory Service](#) as shown in the header of this bulletin.